

ER 42 - 14 pinos

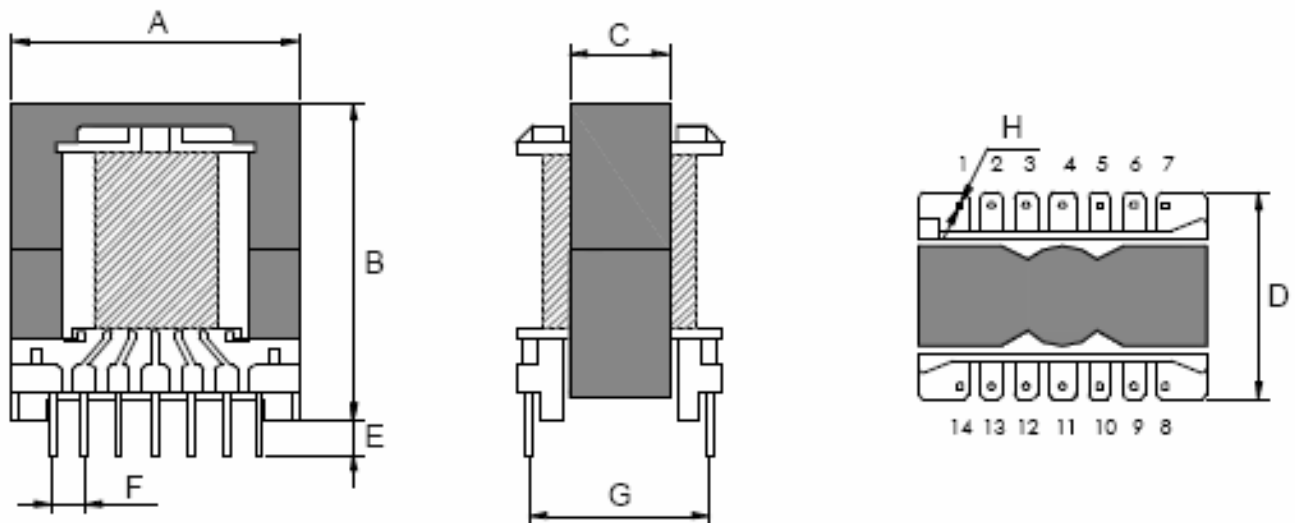

TOLERÂNCIA:  $\pm 0,5\text{mm}$ .

AL:  $4000\text{mH} +30 / -20\%$

ÁREA ÚTIL DA JANELA:  $89,1\text{mm}^2$

CARRETEL	A	B	C	D	E	F	G	H
ER 42 - 14 pinos	42,5	47,7	14,9	29,6	5,0	5,0	25,0	1,0