

E 42 - HORIZONTAL

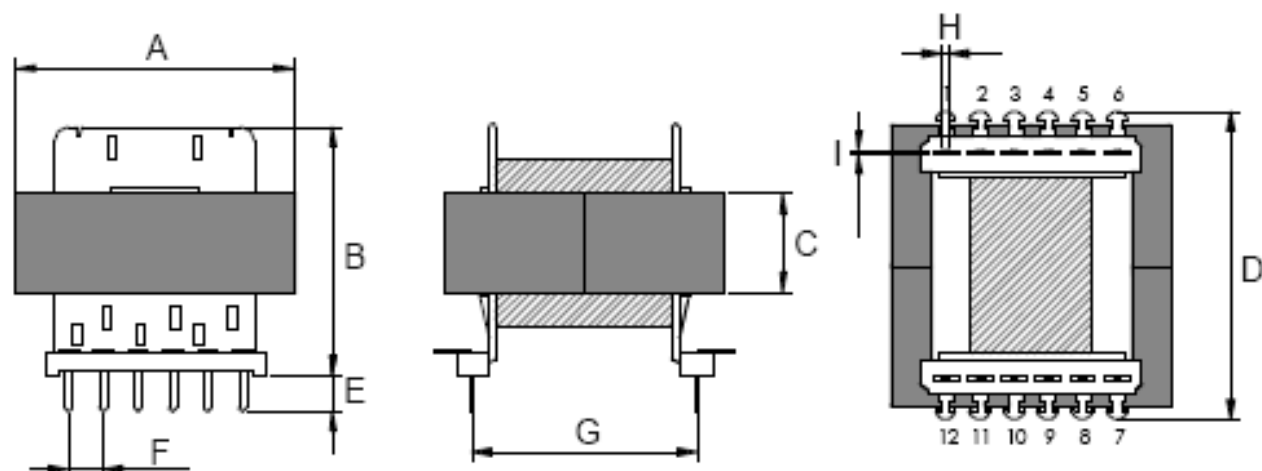

TOLERÂNCIA: $\pm 0,5\text{mm}$.

AL: $4000\text{mH} +30 / -20\%$

ÁREA ÚTIL DA JANELA: $119,2\text{mm}^2$

CARRETEL	A	B	C	D	E	F	G	H	I
E 42/15 - 12 pinos	42,0	36,0	15,0	44,7	5,8	5,0	34,5	1,0	0,4