

E 40 VERTICAL

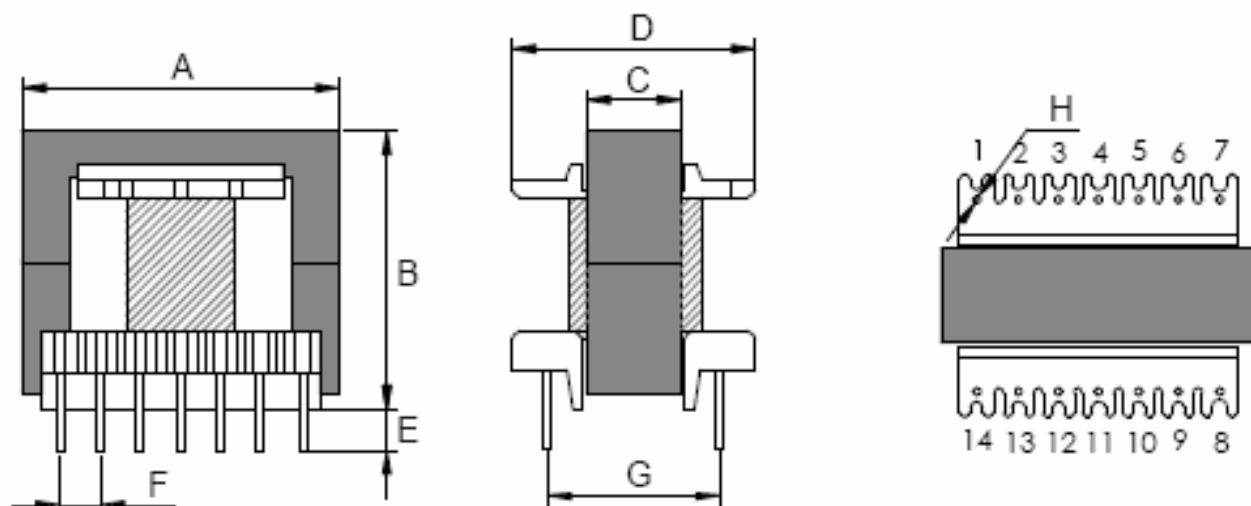

TOLERÂNCIA: $\pm 0,5\text{mm}$.

AL: $3560\text{mH} +30 / -20\%$

ÁREA ÚTIL DA JANELA: $65,0\text{mm}^2$

CARRETEL	A	B	C	D	E	F	G	H
E 40 - 14 pinos	40,5	36,0	12,0	30,0	4,0	5,0	25,0	1,0