

E 40 - HORIZONTAL

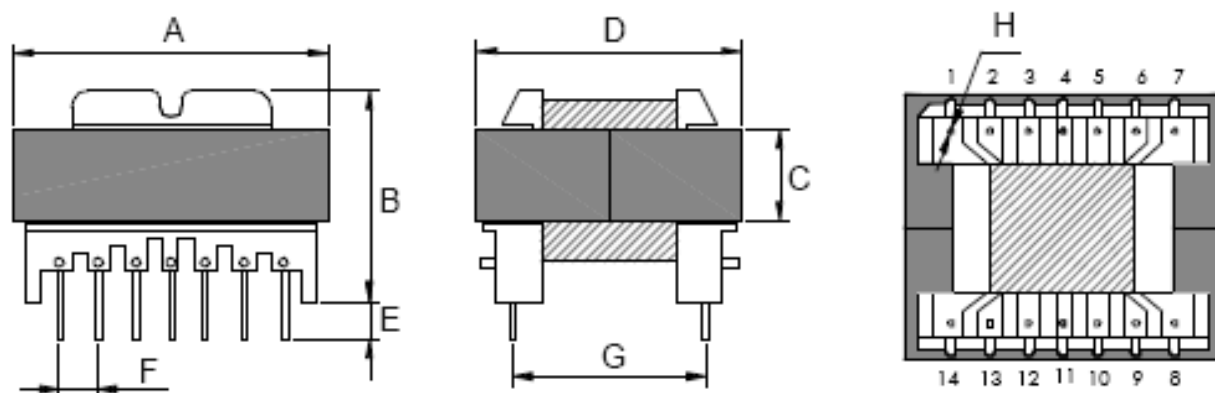

TOLERÂNCIA: $\pm 0,5\text{mm}$.

AL: $3560\text{nH} +30 / -20\%$

ÁREA ÚTIL DA JANELA: $47,0\text{mm}^2$

CARRETEL	A	B	C	D	E	F	G	H
E 40 - 14 pinos	40,5	28,0	12,0	34,5	5,0	5,0	25,6	0,8