

E 40 - VERTICAL

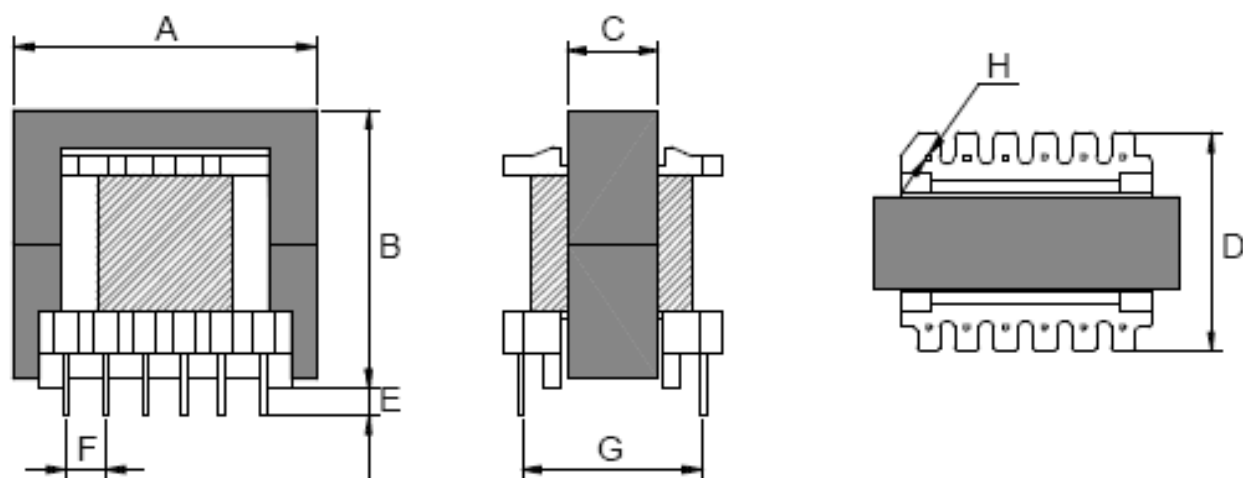

TOLERÂNCIA:  $\pm 0,5\text{mm}$ .

AL:  $3560\text{mH} +30 / -20\%$

ÁREA ÚTIL DA JANELA:  $65,0\text{mm}^2$

CARRETEL	A	B	C	D	E	F	G	H
E 40 - 12 pinos	40,5	35,3	12,0	28,2	5,0	5,0	22,5	0,8