

E 13 - 10 pinos

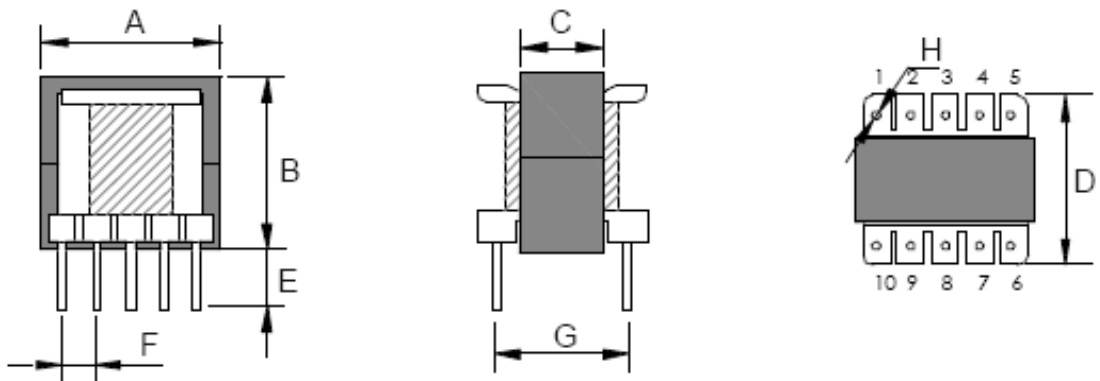

TOLERÂNCIA: +/- 0,5mm.

AL: 1800nH min.

ÁREA ÚTIL DA JANELA: 12,6mm²

CARRETEL	A	B	C	D	E	F	G	H
E 13 - 10 pinos	13,0	12,5	6,0	12,0	4,6	2,6	8,6	0,6