

E 13 - 8 pinos

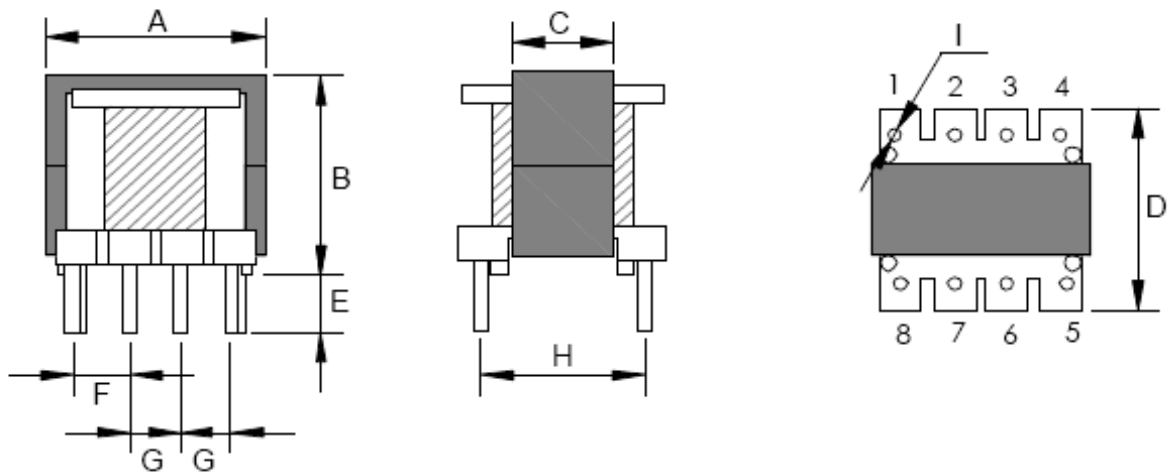

TOLERÂNCIA: $\pm 0,5mm$.

AL: 1800nH min.

ÁREA ÚTIL DA JANELA: 11,5mm²

CARRETEL	A	B	C	D	E	F	G	H	I
E 13 - 8 pinos	13,0	13,2	6,0	13,0	3,8	3,6	3,0	9,5	0,6